

## AN EXPERIMENTAL INVESTIGATION OF THE EFFECT OF WAVES ON VAPOUR SIDE HEAT AND MASS TRANSFER IN FILMWISE CONDENSATION INSIDE A VERTICAL TUBE

P. V. DEO and D. R. WEBB†

University of Manchester Institute of Science and Technology, Sackville Street, Manchester M60 1QD,  
England

(Received 5 May 1981; in revised form 5 May 1982)

**Abstract**—The effect of liquid Reynolds number in condensation of a single vapour from a non-condensing gas has been investigated experimentally. It is apparent that there is no significant enhancement of the heat and mass transfer coefficients on the vapour side up to a liquid film Reynolds number of 200 and a gas Reynolds number of 14,000 in a vertical tube of length 1 metre.

### INTRODUCTION

It is well known that falling liquid films are unstable and waves develop and grow on the surface at all Reynolds numbers. The amplitude of such waves tends to increase with Reynolds number and distance downstream. Such waves would be expected to influence the rate of filmwise condensation. Certainly enhancement of the heat transfer coefficient of the liquid condensate film itself due to film thinning has been investigated experimentally and correlations are available to predict the magnitude of this enhancement.

However it would be expected that the gas side transfer coefficients would also be affected by the presence of waves on the liquid surface. This effect would be particularly important in diffusion controlled condensation of a vapour from a non-condensing gas. It would also be important in falling film reactors where the rate of absorption of a reactant gas is reduced by dilution with a carrier.

Unfortunately the information available in the literature regarding the effect of the wavy nature of the liquid surface on gas side transfer rates is meagre. This paucity of data has prompted the experimental investigation reported in this work. Condensation of one vapour from a non-condensing gas was considered because the bulk temperature drop and the rate of condensation are predominantly dependent on the gas phase heat and mass transfer coefficients. Any enhancement in these rates may be determined by measuring the condensation rate and temperature drop.

### PREVIOUS WORK

The effect of waves on liquid side heat and mass transfer has been investigated by several groups of workers. Notable among these are the work of Banerjee *et al.* (1967) and Ruckenstein & Berbente (1968) on mass transfer and Zozula (1959) and Chun & Seban (1971) on heat transfer.

The effect of the wavy gas-liquid interface on the gas side transfer rates has received little attention in the literature. The following survey covers all the information that appears to be available on this subject.

Stewart & Hurd (1963) carried out condensation of steam-air mixtures in an annulus. They reported heat transfer coefficients,  $h$ , calculated from a naive equation,

$$h = \frac{Q}{A_T(\Delta T)_{lm}} \quad [1a]$$

†Author to whom correspondence should be sent.

In this equation  $Q$  is the total heat transferred in a condenser of total area,  $A_T$ , under the temperature driving force,  $(\Delta T)_{lm}$ , the log mean temperature difference between the bulk gas and the condenser wall. Similarly heat transfer coefficients,  $k$ , were calculated by,

$$k = \frac{W}{A_T(\Delta P)_{lm}} \quad [1b]$$

The total condensation rate,  $W$ , is that realised under the log mean partial pressure difference between the bulk gas and the interface,  $(\Delta P)_{lm}$  where the measured wall temperatures in the condenser were used to evaluate the interfacial partial pressures.

Heat and mass transfer coefficients obtained from [1a] and [1b] were found to be strongly dependent on the condensate film Reynolds number,  $Re_L$ . The results were presented in the form of the Chilton-Colburn  $J_H$ - $J_D$  correlation,

$$J_H = \frac{hC_p}{\dot{G}} \left\{ \frac{\nu}{\alpha} \right\}^{2/3} \quad J_D = \frac{k}{\dot{G}} \left\{ \frac{\nu}{D_{AB}} \right\}^{2/3} \quad [2]$$

In [2],  $\nu$ ,  $\alpha$  and  $D_{AB}$  are momentum, thermal and mass diffusivities respectively,  $C_p$  is the specific heat capacity and  $\dot{G}$  the mass flowrate/unit area of the gas-vapour mixture. Values of  $J_H$  and  $J_D$  were plotted against gas Reynolds Number,  $Re_G$ , with  $Re_L$  as parameter. A strong dependence of  $J_H$  and  $J_D$  upon  $Re_L$  was found for  $Re_L > 40$ .

The heat transfer coefficient,  $h$ , and the mass transfer coefficient,  $k$ , calculated from [1a] and [1b] are not the same as the low flux transfer coefficients,  $h_G$  and  $k_G$ , of the film theory. For a given geometry,  $J_H$  and  $J_D$  based upon  $h_G$  and  $k_G$ , are functions of the hydrodynamics alone and hence are dependent only on the bulk gas Reynolds number  $Re_G$ , and possibly  $Re_L$ . However the same cannot be said about  $J$  factors based on  $h$  and  $k$ . Hence the above result, based on  $h$  and  $k$ , is inconclusive and may be misleading.

Hewitt & Hall Taylor (p. 217, 1970) have stated that, in annular flow in condensation, the vapour liquid interface is roughened and an increase in both heat and mass transfer coefficients may be expected by analogy with increases found for friction factors, but they have not suggested a method for estimating the possible enhancement. They quoted the results of Stewart & Hurd (1963), described above, in support of the above argument. Marschall (1967), on the basis of his experiments on condensation of mixtures of benzene and nitrogen, reported an enhancement factor to heat and mass transfer coefficients given by

$$1 + 0.005 Re_L.$$

Later Lehr (1972), who used the same apparatus as Marschall, reported that his experimental results did not indicate any need for such correction factors.

Johnson & Crynes (1974), in their analysis of falling film reactors, arbitrarily assumed an enhancement factor of 2 to the low flux heat and mass transfer coefficients. The measured reaction rate was predicted closely using this enhancement factor, but no attempt was made to optimise its value. However it appears that the gas phase diffusion does not offer a major resistance in the overall process. Hence the use of this enhancement factor is not entirely justified. Later Davis *et al.* (1979), following Johnson *et al.*, have also used an enhancement factor of 2 in their analysis of falling film reactors but they did not carry out any experiments to support their analysis.

A number of workers (Stern & Votta 1968, Onda *et al.* 1970, Sardesai 1979), have carried out studies of condensation of a vapour in the presence of a non-condensing gas. All their experimental results were in close agreement with film theory predictions, using correlations for heat and mass transfer coefficients, which did not take into account any enhancement to heat

and mass transfer coefficients. Recently Owen *et al.* (1980) have also published experimental results which exhibit no enhancement of vapour side heat transfer in condensation. To sum up, all the experimental studies which suggest the use of enhancement factors are inconclusive. They either lack rigorous analysis or they were not designed to investigate such enhancement. On the other hand many studies of condensation appear to suggest that no enhancement of the condensation rates occurs as a result of the presence of a condensate. This surprising result is the subject of the present study.

#### EXPERIMENTAL APPARATUS

The experimental apparatus used in this work consists of a test condenser, shown in figure 1, in which gas-vapour mixtures can be condensed inside a vertical tube of 1 m length and 0.0225 m i.d. Condensed liquid may be recirculated to the top of the condenser to flow down the walls as shown in figure 2. Cooling water is circulated through a jacket surrounding the inner tube. The jacket is well insulated to reduce energy losses by heat transfer to the atmosphere. Condensate formed flows down the inner surface of the inner tube and is removed through a condensate collection ring.

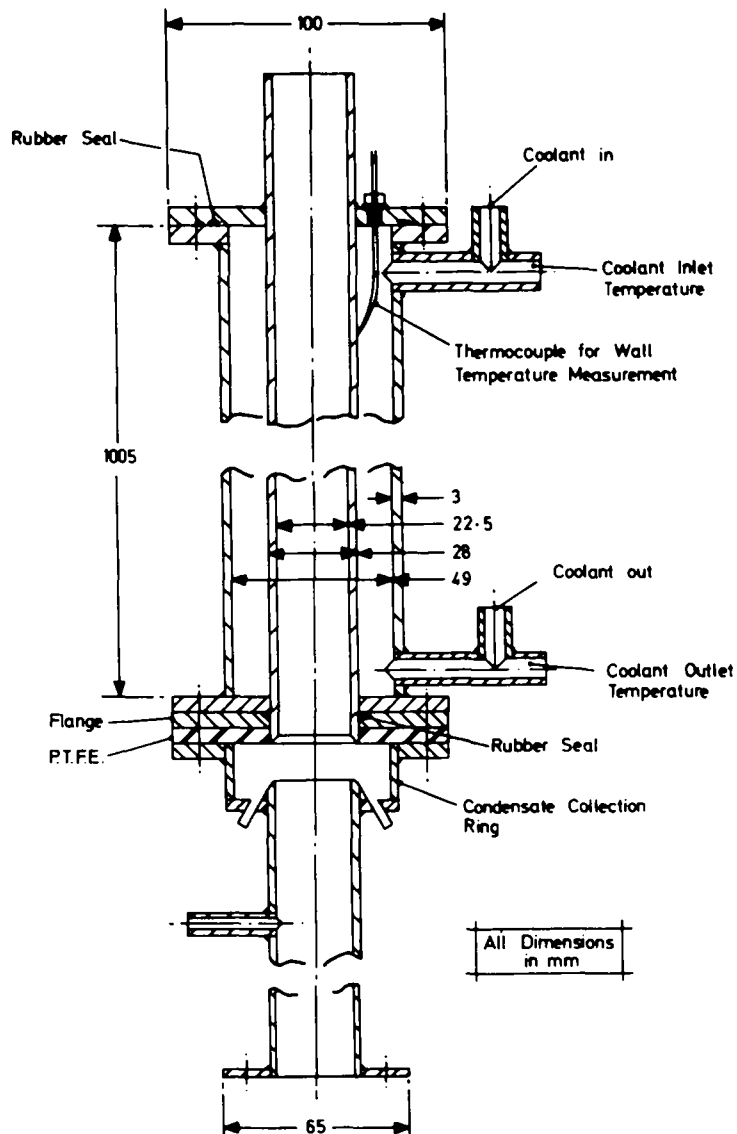

Figure 1. Test condenser.



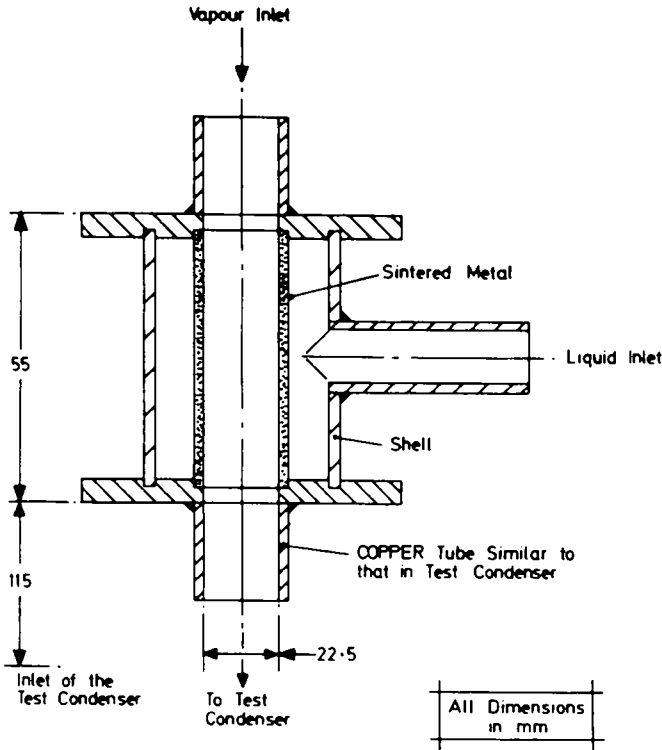

Figure 3. Liquid distributor.

a mixture of iso-propanol and nitrogen, (table 1). In each series of experiments, liquid recirculation rate was varied (thus varying  $Re_L$ ) while the other inlet conditions viz. gas-vapour flow rate, composition, coolant flow rate and temperature were kept constant. The following quantities were measured experimentally: (1) gas flow rate,  $G$ ; (2) vapour flow rate,  $G_A$ ; (3) test condenser inlet and outlet temperatures; (4) test condenser wall temperatures; (5) coolant flow rate; (6) coolant inlet and outlet temperatures; (7) liquid flow rate; (8) liquid inlet flow rate; (9) condensation rate in the test condenser; (10) condensation rate in the after condenser; (11) after condenser outlet temperature.

#### PREDICTION OF THE CONDENSER PERFORMANCE

A computer program was written to predict the development of vapour flow rate, composition and temperature and condensate and coolant temperature through the test condenser. A film model was used in this program to evaluate heat and mass transfer rates at any point along the axis of the condenser. The local low flux heat and mass transfer coefficients were evaluated using the Chilton-Colburn analogy and the correlation,

$$J_H = J_D = 0.023 Re_G^{-0.2}. \quad [3]$$

It should be noted that [3] is a well established correlation for flow inside a smooth tube and does not take into account any enhancement due to waves on the surface of the condensate film.

Figure 4 shows in detail the physical model (and defines the nomenclature) that was used in the calculation of the local heat and mass transfer rates. At any downstream location the gas temperature,  $T_G$ , and composition of condensing constituent  $A$ ,  $y_{AG}$ , the coolant temperature,  $T_c$ , and the mean condensate temperature,  $\bar{T}_L$ , will be specified. Interfacial temperature,  $T_I$ , and

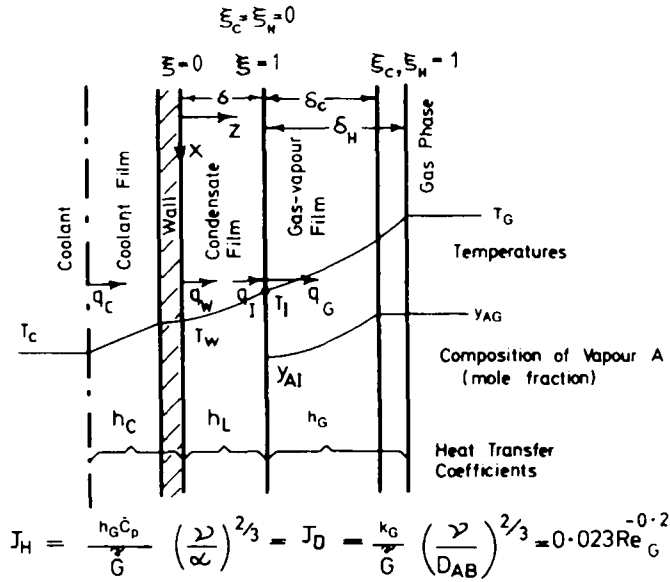

Fig. 4. Film model.

wall temperature,  $T_w$ , must be found so that energy flux is continuous at the wall and interface. The mass and energy transfer rates are then uniquely determined.

A film model is assumed in the gas-vapour films. For the  $Z$  coordinate system shown in figure 4, the temperature profile,  $T(\xi_H)$ , composition profile by mole fraction,  $y_A(\xi_C)$ , follow with  $\xi$  defined as the fractional distance across the film under consideration.

$$\frac{(T - T_i)}{(T_G - T_i)} = \left\{ \frac{\exp(\epsilon \xi_H) - 1}{\exp \epsilon - 1} \right\} \text{ where } \xi_H \equiv \frac{(Z - \delta)}{\delta_H} \in [0, 1] \quad [4]$$

$$\frac{(y_A - y_{AI})}{(y_{AG} - y_{AI})} = \left\{ \frac{\exp(\phi \xi_C) - 1}{\exp \phi - 1} \right\} \text{ where } \xi_C \equiv \frac{(Z - \delta)}{\delta_C} \in [0, 1]. \quad [5]$$

In these equations, Ackermann type factors,  $\epsilon$  and  $\phi$ , defined as follows, account for the convection of species  $A$  across the film at a molar flux,  $N_A$ .

$$\epsilon = N_A \tilde{C}_{pA} / h_G \quad \phi = N_A / k_G \quad [6]$$

where  $\tilde{C}_{pA}$  is the molar specific heat capacity of  $A$  at constant pressure. The heat transfer coefficient,  $h_G$ , and the mass transfer coefficient,  $k_G$  are calculated by the  $J_H$ - $J_D$  correlation stated below figure 4, with  $\tilde{G}$  the molar gas flowrate/unit area and other symbols defined below [2].

The molar flux of condensation,  $N_A$ , and the conductive heat flux in the gas film at the interface,  $q_G$ , follow directly from [4] and [5],

$$N_A = k_G \ln \left\{ \frac{1 - y_{AG}}{1 - y_{AI}} \right\} \quad [7]$$

$$q_G = h_G \frac{\epsilon}{e^\epsilon - 1} (T_i - T_G). \quad [8]$$

The analysis of the heat transfer process in the condensate film must account for subcooling. In many of the runs substantial quantities of the condensing species at ambient temperature

were introduced through the liquid distributor to establish the flow down the condenser wall. The effect will be that the conductive heat fluxes in the condensate at the wall,  $q_w$  and interface,  $q_i$ , will differ. In the analysis of heat transfer in the condensate it is assumed that the profile of downstream velocity,  $V_x(Z)$ , is that which would be found in a laminar film of uniform thickness having the same volumetric flowrate per wetted periphery,  $\Gamma$ . With  $g$  the acceleration of gravity and  $\nu$  the kinematic viscosity of the condensate,

$$V_x = \frac{g}{\nu} \{ \delta Z - Z^2/2 \} \quad Z \in [0, \delta]$$

$$\Gamma = g\delta^3/3\nu. \quad [9]$$

The temperature profile across the condensate,  $T(\xi)$ , was assumed to have a quadratic form and the coefficients of the polynomial, ( $a$ ,  $b$  &  $c$ ), chosen to fit the boundary conditions.

$$\frac{(T - T_w)}{(T_i - T_w)} = a + b\xi + c\xi^2 \quad \xi = \frac{Z}{\delta} \in [0, 1]$$

$$= \xi(b - b\xi + \xi). \quad [10]$$

The mixing cup temperature,  $\bar{T}_L$ , may be obtained in terms of  $b$  from the definition,

$$\frac{(\bar{T}_L - T_w)}{(T_i - T_w)} = \int_0^\delta \frac{(T - T_w)}{(T_i - T_w)} V_x dZ / \int_0^\delta V_x dZ = \left\{ 0.45 + \frac{7b}{40} \right\}. \quad [11]$$

The conditions of energy continuity across wall and interface may now be written in terms of the various conductive heat fluxes shown in figure 4, and the latent heat contribution,  $\lambda_A N_A$ .

$$q_i = \lambda_A N_A + h_G \frac{\epsilon}{(e^\epsilon - 1)} (T_i - T_G) = h_L(2 - b)(T_w - T_i) \quad [12]$$

$$q_c = h_c(T_c - T_w) = q_w = h_L b(T_w - T_i). \quad [13]$$

Equations [12] and [13] allow  $T_w$  and  $T_i$  to be determined if,  $\bar{T}_L$ ,  $T_G$ ,  $T_c$  and  $y_{AG}$  are known. The interfacial composition,  $y_{Ai}$ , is obtained with the assumption of interfacial equilibrium, from the vapour pressure of  $A$ ,  $P_A^\circ$ , and the system pressure,  $P_T$ .

$$y_{Ai} = P_A^\circ(T_i)/P_T. \quad [14]$$

Coolant and condensate heat transfer coefficients must be known. That of the coolant is determined by a correlation appropriate for the given geometry, while that of the condensate is obtained from the condensate thermal conductivity, and the Nusselt film thickness, [9].

Condenser design requires a set of ordinary differential equations, differential mass and energy balances, showing how  $\bar{T}_L$ ,  $T_G$ ,  $T_c$  and  $y_{AG}$  vary through the condenser with the independent variable,  $A$ , the cumulative condenser area. It is readily shown that molar gas flowrates of species  $A$  and  $B$ ,  $\tilde{G}_A$  and  $\tilde{G}_B$ , respectively and the molar flowrate of condensate,  $\tilde{G}_L$ , are given by,

$$\frac{d\tilde{G}_A}{dA} = N_A = -\frac{d\tilde{G}_L}{dA}$$

$$\frac{d\tilde{G}_B}{dA} = 0. \quad [15]$$

Hence the molar gas composition,  $y_{AG}$ , follows as

$$y_{AG} = \tilde{G}_A / (\tilde{G}_A + \tilde{G}_B) = \tilde{G}_A / \tilde{G}. \quad [16]$$

Differential energy balances in the gas-vapour phase and coolant give the temperature,  $T_G$  and  $T_c$  respectively as,

$$\tilde{G} \tilde{C}_{pG} \frac{dT_G}{dA} = h_G \frac{e^\epsilon \epsilon}{(e^\epsilon - 1)} (T_I - T_G) \quad [17]$$

$$G_c C_{pc} \frac{dT_c}{dA} = \pm h_c (T_c - T_w) \quad [18]$$

where the sign in [18] is positive if coolant and condensate are in cocurrent flow and negative if they are in counter current flow. In [18]  $G_c$  is the mass flowrate of the coolant and  $C_{pc}$  its specific heat capacity.

Finally the downstream development of the mixing temperature of the condensate,  $\bar{T}_L$ , may be determined from the energy equation applied to the condensate,

$$\rho_L C_{pL} \left\{ V_x \frac{\partial T}{\partial x} + V_z \frac{\partial T}{\partial z} \right\} = k_L \frac{\partial^2 T}{\partial z^2} \quad [19]$$

where  $\rho_L$ ,  $C_{pL}$  and  $k_L$  are the density, specific heat capacity and thermal conductivity of the condensate. This analysis was carried out to two approximations. In the first approximation it was assumed that the normal velocity,  $V_z$ , was zero while in the second its variation was included. With an integral method treatment of the condensate it can be shown that,

$$\rho_L \tilde{C}_{pL} \left\{ \Gamma \frac{d\bar{T}_L}{dx} + (\bar{T}_L - T_I) \frac{d\Gamma}{dx} \right\} = (q_w - q_I) \quad [20]$$

and hence

$$\tilde{G}_L \tilde{C}_{pL} \frac{d\bar{T}_L}{dA} = \left[ 2h_L(1-b) - N_A \tilde{C}_{pL} \left\{ 0.55 - \frac{7b}{40} \right\} \right] (T_I - T_w). \quad [21]$$

The first term alone of the r.h.s. appears in the first approximation, while both appear in the second approximation.

The above set of equations, of which [15], [17], [18] and [21] are independent, were integrated using a Runge-Kutta-Merson technique, with experimental measurements at the vapour inlet providing the initial conditions of the boundary value problem. Values of dependent variables were determined at  $A = A_T$ , the vapour outlet from the condenser. It was apparent that little was to be gained using the second approximation in [21], the effect on the computed solution being less than 1%.

## RESULTS AND DISCUSSION

Altogether 17 runs were carried out with the system Isopropanol-Nitrogen. The experimental conditions and condensation rates for all runs are given in table 1. These runs may be divided into 3 groups as follows:

*Group I.* Run numbers 1-5

*Group II.* Run numbers 6-8

*Group III.* Run numbers 9-17.



Table 1. System isopropanol (A)-nitrogen (B)

	INLET CONDITIONS				OUTLET CONDITIONS			$Re_L$	
	GAS RATE $\times 10^5$ (kmol/s)	$Y_{AG}$	$Re_G$	GAS TEMP. $T_G$ (K)	COOLANT TEMP. $T_c$ (K)	CONDENSA- TION RATE $\times 10^5$ (kmol/s)	GAS TEMP. $T_G$ (K)		COOLANT TEMP. $T_c$ (K)
1	8.29	.42	12970	356.6	292.5	1.29	338.9	296.4	15.4
2	8.19	.43	13460	345.7	295.2	1.43	332.0	299.1	37.9
3	8.20	.43	13680	342.2	298.7	1.40	331.4	302.5	46.4
4	8.86	.45	13710	344.7	291.0	1.41	332.2	295.0	68.8
5	8.66	.45	13650	346.4	289.8	1.42	332.1	293.8	95.4
6	8.27	.40	12720	354.1	289.5	1.36	331.4	292.9	79.6
7	8.28	.40	12440	363.4	289.6	1.32	339.0	295.9	48.0
8	8.28	.40	12310	368.2	289.7	1.27	340.8	293.7	14.0
9	6.68	.41	10200	365.5	296.6	1.04	340.0	299.6	12.7
10	6.61	.41	10070	362.7	296.9	1.10	338.0	300.1	26.1
11	6.61	.41	10110	361.4	296.5	1.05	337.5	299.8	61.4
12	6.61	.41	10070	362.5	296.4	.99	338.1	299.7	66.2
13	6.61	.40	10040	362.7	295.6	.96	337.1	298.9	85.2
14	6.62	.40	9950	364.9	292.1	1.13	338.8	296.4	11.8
15	6.60	.40	10020	363.2	291.6	1.03	337.4	294.8	116.7
16	6.61	.40	10000	362.8	291.3	1.04	336.8	294.3	162.9
17	6.60	.40	9970	363.4	291.3	1.02	336.0	293.9	204.5

FOR ALL RUNS COOLANT FLOW RATE = .0394 KG/SEC

For each group, the gas flow rate and the vapour flow rate are almost constant, while the recirculating liquid flow rate varies over a wide range (Thus producing a wide variation in  $Re_L$  from 10–200). Run numbers 1, 8, 9 and 14 were carried out without recirculating liquid. The liquid Reynolds numbers reported are based on the average of inlet and outlet liquid flow rates.

There are three resistances to heat transfer in condensation of a vapour from a non-condensing gas. These are the resistances of the condensate film and of the hypothetical films in the vapour and coolant, see figure 4. Under the conditions of this study, (table 1), the inlet concentration of non-condensing gas is large (0.55–0.6 by mole fraction). In consequence the vapour film dominates and errors in estimating the resistances of the coolant and condensate are not of major importance. The condensate coefficient is probably the major source of error because wave enhancement has not been included.

The condensation rates and bulk gas–vapour temperature drops were predicted using a computer program details of which are described previously. The low flux heat and mass transfer coefficients were obtained from [3]. As pointed out this correlation has been widely used in the literature and does not take into account enhancement due to waves on the condensate surface.

The experimental and predicted condensation rates and temperature drops are compared in Table 2. For ease of comparison, runs in each group are arranged in ascending order of  $Re_L$ . The predicted temperature drops are also compared with experimental values in figure 5.

It is apparent that the predicted condensation rates are in excellent agreement with the experimental values irrespective of the value of  $Re_L$ . The temperature drops are also predicted reasonably well (within  $\pm 20\%$ ; for the majority of runs this deviation is much less than 20%). It is clear then that there is no significant enhancement in the heat and mass transfer rates in the vapour phase due to waves on the surface of the condensate film, for the range of  $Re_L$  studied. It is known that the disturbances on the surface of falling films increase not only with  $Re_L$ , but also with downstream distance from the liquid distributor. Hence the conclusions drawn above are true only for the experimental geometry examined, i.e. where the downstream distances are less than 1 m. Thus for the geometry examined it may be concluded that there is no

Table 2.

RUN NO.	$Re_G$	$Re_L$	CONDENSATE RATE $\times 10^5$ (kmol/s)		TEMP. DROP (K)		
			EXPTL	PREDICTED	EXPTL	PREDICTED	
1	12970	15.4	1.29	1.25	17.7	16.9	GROUP I
2	13460	37.9	1.43	1.29	13.7	12.2	
3	13680	46.4	1.40	1.27	10.8	10.0	
4	13710	68.8	1.41	1.46	12.5	11.9	
5	13650	95.4	1.42	1.47	14.3	12.7	
8	12310	14.0	1.27	1.18	27.4	23.1	GROUP II
7	12440	48.0	1.32	1.21	24.4	22.7	
6	12720	79.6	1.36	1.24	22.7	18.3	
14	9950	11.8	1.13	1.03	26.1	23.1	GROUP III
9	10200	12.7	1.04	1.01	25.4	21.6	
10	10070	26.1	1.10	1.09	24.7	23.5	
11	10110	61.4	1.05	1.02	24.0	21.9	
12	10070	66.2	0.99	1.00	24.4	22.2	
13	10040	85.2	0.96	1.01	25.7	22.5	
15	10020	116.7	1.03	1.05	25.8	23.3	
16	10000	162.9	1.04	1.03	26.1	23.2	
17	9970	204.5	1.02	1.02	27.4	23.3	

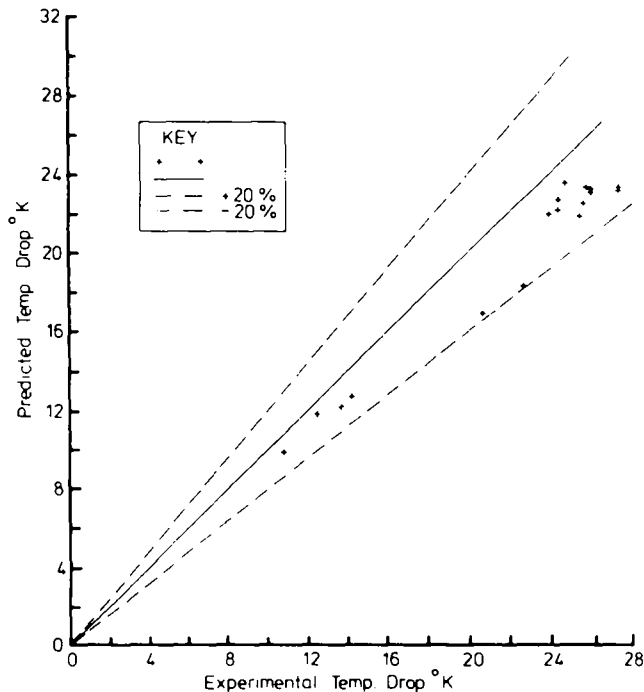

Figure 5. Experimental in predicted temperature drop.

enhancement of gas phase heat and mass transfer rates, up to  $Re_L$  of 200,  $Re_G$  of 14,000 and downstream distances of 1 m, due to disturbances on the surface of a falling liquid film. Further for the case of condensation in the presence of a non-condensing gas,  $Re_L$  of 200 represents a rather high rate of condensation. Hence at least for this case, it is not necessary to take into account any enhancement in the gas phase heat and mass transfer rates.

The absence of wave enhancement is surprising particularly in view of the wide range of liquid flowrates used. In Group III results of table 2, the condensate Reynolds number was varied from about 10 to 200, a twenty fold variation. Assuming a uniform, laminar condensate film this would have resulted in about a 2.5 fold change in condensate thickness ( $\alpha Re^{1/3}$ ) and a seven fold change in average velocity ( $\alpha Re^{2/3}$ ), though this velocity was always less than 1% of the superficial gas velocity. Clearly such large variations of conditions at the wavy interface may produce compensating effects in which a wave enhancement is offset by other factors and it may merely be a fortunate condition that the rather crude film model is adequate for modelling the heat and mass transfer rates.

#### CONCLUSIONS

A systematic experimental investigation has been carried out to study the influence of disturbances on the surface of falling liquid films on the gas side heat and mass transfer rates. The system used is the condensation of a vapour in the presence of a non-condensing gas. In such a system condensation rate and bulk gas phase temperature drop are predominantly controlled by gas side heat and mass transfer rates.

The results from the experiments mentioned above, suggest that there is no significant enhancement in gas side heat and mass transfer rates up to a condensate film Reynolds number of 200, gas Reynolds number of 14,000, and downstream distance of 1 m. Hence the correlations for evaluation of low flux heat and mass transfer coefficients, which do not take into account any enhancement due to disturbances on the condensate film surface, may be used in predicting performance of a condenser, for the case of condensation in the presence of a non-condensing gas.

This is in agreement with the similar conclusion reached by Owen *et al.* (1980). Both studies are of condensation on a vertical surface under conditions of low surface shear. (A gas Reynolds number inside a tube of less than 14,000 in this study). There may well be enhancement under gas shear dominated conditions at higher gas Reynolds number. Further this study is limited to condensation in cocurrent downwards flow inside a vertical tube and does not apply to other geometries or conditions in which condensate is detached from the surface by gravity or surface shear.

#### REFERENCES

- BANERJEE, S., RHODES, E. & SCOTT, D. S. 1967 Mass transfer to falling wavy liquid films at low Reynolds numbers. *Chem. Engng Sci.* **22**, 43–48.
- CHUN, K. R. & SEBAN, R. A. 1971 Heat transfer to evaporating liquid films. *J. Heat Transfer Trans ASME* **93**, 391–396.
- DAVIS, E. J., VAN OUWERKERK, M. & VENKATESH, S. 1979 An analysis of the falling film gas-liquid reactor. *Chem. Engng Sci.* **34**, 539–550.
- DEO, P. V. 1979 Condensation of mixed vapours. Ph.D. Thesis, UMIST, University of Manchester.
- HEWITT, G. F. & HALL TAYLOR, N. S. 1970 *Annular Two Phase Flow*. Pergamon Press, Oxford.
- JOHNSON, G. R. & CRYNES, B. L. 1974 Modelling a thin film sulphur trioxide sulphonation reactor. *Ind. Engng Chem. Proc. Des. Dev.* **13**, 6–14.
- LEHR, G. 1972 Heat and mass transfer in the condensation of two vapours out of an inert gas. Ph.D. Thesis, Technological University of Hanover.
- MARSCHALL, E. 1967 Mass transfer in the condensation of steam from a gas mixture. *Kaltetechnik*, **19**(8), 241–245.
- ONDA, K., SADA, E. & TAKAHASHI, K. 1970 The film condensation of mixed vapours in a vertical column. *Int. J. Heat Mass Transfer* **13**, 1415–1424.
- OWEN, R. G., SARDESAI, R. G. & PULLING, D. J. 1980 Heat and mass transfer coefficients for the

- condensation of binary mixtures in a vertical tube. *19th Nat. Heat Transfer Conf.* Orlando, Florida.
- RUCKENSTEIN, E. & BERBENTE, C. 1968 Mass transfer to falling liquid films at low Reynolds numbers. *Int. J. Heat Mass Transfer* **11**, 743-753.
- STERN, F. & VOTTA F. 1968 Condensation from superheated gas-vapor mixtures. *AIChE J.* **14**, 928-933.
- SARDESAI, R. G. 1979 Studies in condensation. Ph.D. Thesis, UMIST, University of Manchester.
- STEWART, P. B. & HURD, S. E. 1963 *Condensing heat transfer in steam-air mixtures in turbulent flow: Reynolds number relationships*. Sea Water Conversion Laboratory Report No. 635, Contribution No. 71, University of California.
- ZOZULA, M. V. 1959 *Heat Transfer and Thermal Modelling*", (Edited by M. A. Mikheer), *Akad. Nauk. SSSR*, 287, Moscow. (DSIR Trans. No. 668).